



**SOLUCIONES
TÉCNICAS
PARA EL MUEBLE**

20
23

09

**Sistemas
herrajes
cocina**
Kitchen
hardware
systems





**SOLUCIONES
TÉCNICAS
PARA EL MUEBLE**

20
23

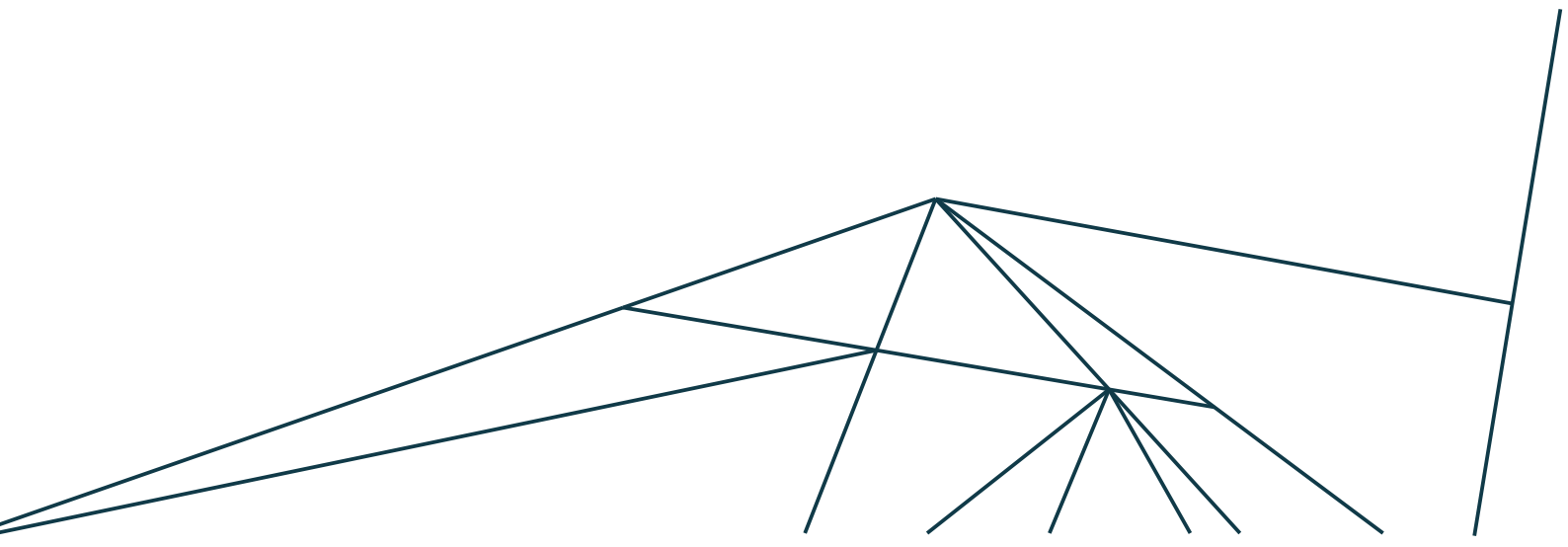

STM Soluciones Técnicas para el Mueble, S.L.

Toda empresa nace de una idea, una idea acerca de la FABRICACIÓN de un producto o la prestación de un servicio que permita satisfacer la necesidad de alguien, el futuro cliente. Cuando se tiene una idea relativa al desarrollo de una actividad empresarial, ya se ha dado el primer paso para crear una empresa; cuando aún no se tiene, lo primero que se debe hacer es buscarla. Pero la idea difícilmente se concretará en una empresa si no está apoyada en una actitud personal: la ilusión; ilusión y entusiasmo por crear algo nuevo, por iniciar una aventura que para algunos durará y marcará toda su vida.

Every company is born from an idea, an idea about the MANUFACTURE of a product or the provision of a service that allows satisfying the need of someone, the future client. When you have an idea regarding the development of a business activity, you have already taken the first step to create a company; when you don't have it yet, the first thing to do is look for it. But the idea will hardly materialize in a company if it is not supported by a personal attitude: illusion; illusion and enthusiasm to create something new, to start an adventure that for some will last and mark their entire lives.

En STM SOLUCIONES, la reflexión acerca de qué vamos a ofrecer al cliente supone pensar también en cómo cambiar el producto o servicio que ya está siendo ofrecido. Ello exige llegar a comprender con profundidad las necesidades y expectativas de nuestros clientes tanto presentes como futuros, pues sólo la empresa que conoce adecuadamente estas necesidades está en condiciones de poder ofrecer un producto que las satisfaga.

In STM SOLUCIONES, thinking about what we are going to offer the customer also means thinking about how to change the product or service that is already being offered. This requires an in-depth understanding of the needs and expectations of our customers, both present and future, since only the company that adequately understands these needs is in a position to offer a product that satisfies them.

En esta reflexión para conseguir diferenciarnos de nuestros competidores y gracias al apoyo de nuestros colaboradores (clientes, proveedores, personal...), hemos empleado toda nuestra creatividad e imaginación, pero considerando siempre la factibilidad práctica de estas ideas.

In this requires an in-depth understanding of the needs and expectations of our customers, both present and future, since only the company that adequately understands these needs is in a position to offer a product that satisfies them.

Servicio, atención al cliente, producto actual y un equipo humano profesional, son los 4 pilares básicos que hacen que esta empresa fundada en el año 2013 se mantenga en creciente expansión.

Service, customer care, current product and a professional human team, are the 4 basic pillars that make this company founded in 2013 keep growing.



2023

10
years
ANNIVERSARY



09

**Sistemas
herrajes
cocina**

Kitchen
hardware
systems

SERIE SQUAD

SQUAD SERIES

Pag.: 9.4



Pag.: 9.5



Pag.: 9.5



Pag.: 9.5



Pag.: 9.6



Pag.: 9.7



Pag.: 9.8



Pag.: 9.9



Pag.: 9.10



SERIE Sous-Chef

Sous-Chef SERIES

Pag.: 9.11



Pag.: 9.12



Pag.: 9.13



Pag.: 9.14



Pag.: 9.15



Pag.: 9.16



Pag.: 9.17



Pag.: 9.18

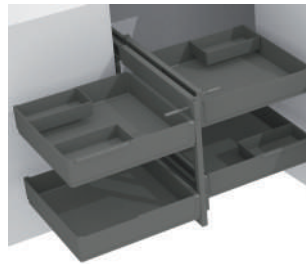

Pag.: 9.20



Pag.: 9.22



ESCURREPLATOS SHARK

PLATE RACK SHARK



KIT192S/NMZNS	450 MM.	Individual / Single
KIT192S2/NMZNS	450 MM.	Doble / Double
KIT193S/NMZNS	600 MM.	Individual / Single
KIT193S2/NMZNS	600 MM.	Doble / Double
KIT194S/NMZNS	800 MM.	Individual / Single
KIT194S2/NMZNS	800 MM.	Doble / Double
KIT195S/NMZNS	900 MM.	Individual / Single
KIT195S2/NMZNS	900 MM.	Doble / Double
KIT196S/NMZNMZ	1000 MM.	Individual / Single
KIT196S2/NMZNMZ	1000 MM.	Doble / Double
KIT197S/NMZNMZ	1200 MM.	Individual / Single
KIT197S2/NMZNMZ	1200 MM.	Doble / Double



El escurreplatos de diseño súper moderno y que ahorra espacio, utiliza un sólo estante para platos y vasos con bandas grandes y sólidas.

The Rack with a super modern and space-saving design, utilizing a single rack for dishes and glasses with large and solid bands.

Combi Shark Antracita PRETRATADO CON MATERIAL ANTIOXIDANTE + marco de aluminio anodizado 230SG embalado en caja individual con bandeja recoge-aguas en acrílico para medidas inferiores a 900 mm. y en acero inoxidable para las medidas de 1000 y 1200 mm.

Combi Shark Anthracite PRE-TREATED WITH ANTIOXIDANT MATERIAL + 230SG anodized aluminum frame packed in individual box with acrylic drip tray for measurements less than 900 mm. and in stainless steel for the measures of 1000 and 1200 mm.

BOTELLERO / PANERO / TOALLERO 150 MM

BOTTLE / BREAD / TOWEL RACK 150 MM



Q-352NMH	150 mm (L110xP500xH570 mm)
Q-336NMH	150 mm (L110xP500xH570 mm)
Q-352NMPCH	150 mm (L110xP500xH570 mm)

Portabotellas, Panero-botellero o Toallero-botellero extraíble JOLLY, extracción total con cierre amortiguado Hettich V6.

Bottle holder, Bread-bottle rack or JOLLY pull-out towel rack-bottle rack, total extraction with Hettich V6 soft closing.

Acabado antracita PRETRATADO CON MATERIAL ANTIOXIDANTE.

Anthracite finish PRETREATED WITH ANTI-RUST MATERIAL.



BOTELLERO SQUAD

SQUAD BOTTLE RACK



Q-363MNH	200 mm (L164xP500xH570 mm)
Q-DIV363	Divisor / Divider
T-Q363	Alf. antideslizante / Non-slip mat
Q-311MNH	300 mm (L264xP500xH570 mm)
Q-DIV311	Divisor / Divider
T-Q311	Alf. antideslizante / Non-slip mat
Q-325MNH	350 mm (L314xP500xH570 mm)
Q-DIV325	Divisor / Divider
T-Q325	Alf. antideslizante / Non-slip mat
Q-321MNH	400 mm (L364xP500xH570 mm)
Q-DIV321	Divisor / Divider
T-Q321	Alf. antideslizante / Non-slip mat
Q-323MNH	450 mm (L414xP500xH570 mm)
Q-DIV323	Divisor / Divider
T-Q323	Alf. antideslizante / Non-slip mat
Q-324MNH	600 mm (L564xP500xH570 mm)
Q-DIV324	Divisor / Divider
T-Q324	Alf. antideslizante / Non-slip mat



Portabotellas, extracción total con cierre amortiguado Hettich V6.
 Bottle holder, total extraction with Hettich V6 soft closing.

Acabado antracita PRETRATADO CON MATERIAL ANTIOXIDANTE.
 Anthracite finish PRETREATED WITH ANTI-RUST MATERIAL.

BOTELLERO-PANERO SQUAD

SQUAD BOTTLE-BREAD RACK



Q-331MNH	300 mm (L264xP500xH570 mm)
Q-DIV311	Divisor / Divider
T-Q331	Alf. antideslizante / Non-slip mat
Q-335MNH	350 mm (L314xP500xH570 mm)
Q-DIV325	Divisor / Divider
T-Q335	Alf. antideslizante / Non-slip mat
Q-332MNH	400 mm (L364xP500xH570 mm)
Q-DIV321	Divisor / Divider
T-Q332	Alf. antideslizante / Non-slip mat
Q-333MNH	450 mm (L414xP500xH570 mm)
Q-DIV323	Divisor / Divider
T-Q333	Alf. antideslizante / Non-slip mat
Q-334MNH	600 mm (L564xP500xH570 mm)
Q-DIV324	Divisor / Divider
T-Q334	Alf. antideslizante / Non-slip mat



Portabotellas, extracción total con cierre amortiguado Hettich V6.
Bottle holder, total extraction with Hettich V6 soft closing.

Acabado antracita PRETRATADO CON MATERIAL ANTIOXIDANTE.
Anthracite finish PRETREATED WITH ANTI-RUST MATERIAL.

MECANISMO SQUAD MUEBLE DE ESQUINA

SQUAD MECHANISM CORNER CABINET



Q-674NMSDA
T-Q674

CORNER (L700xP500xH620 mm)
Alf. antideslizante / Non-slip mat



Mecanismo extraíble SQUAD reversible para esquina.

Funcionalidad y practicidad, todo en un sólo producto.

El mecanismo SQUAD es reversible (derecha e izquierda), con sus cestas de extracción total para aprovechar mejor el espacio y dejarlo todo al alcance de la mano. El cierre amortiguado asegura la continuidad así como una perfecta armonía.

SQUAD Pull out reversible mechanism for corner.

Functionality and handiness, all in one product.

The SQUAD mechanism is reversible (right and left), with its full extension baskets to better utilize the space and leave everything at your fingertips. The return is damped to ensure continuity and perfect harmony.

Acabado antracita PRETRATADO CON MATERIAL ANTIOXIDANTE.

Anthracite finish PRETREATED WITH ANTI-RUST MATERIAL.



COLUMNA EXTRAIBLE SQUAD

SQUAD BOTTLE-BREAD RACK



Q-411NM/30	300 mm (L240xP490xH1200/1450 mm)
Q-411NM/40	400 mm (L340xP490xH1200/1450 mm)
Q-411NM/45	450 mm (L390xP490xH1200/1450 mm)
Q-412NM/30	300 mm (L240xP490xH1900/2100 mm)
Q-412NM/40	400 mm (L340xP490xH1900/2100 mm)
Q-412NM/45	450 mm (L390xP490xH1900/2100 mm)
T-Q421/30	Alf. antideslizante / Non-slip mat
T-Q422/40	Alf. antideslizante / Non-slip mat
T-Q423/45	Alf. antideslizante / Non-slip mat



Las columnas extraíbles que aprovechan la altura, son la solución ideal si quieres espacios ordenados y bien organizados.

El set consta de bastidor central regulable, guías de extracción total y cestas (4 ud. para altura 1200/1450mm. y 5 unidades para altura 1900/2100 mm.)

The pull out columns, taking advantage of the height, are the ideal solution if you want tidy and well organized spaces.

The set consists of an adjustable central frame, total extraction guides and baskets (4 units for height 1200/1450mm. and 5 units for height 1900/2100mm.).

Acabado antracita PRETRATADO CON MATERIAL ANTIOXIDANTE.

Anthracite finish PRETREATED WITH ANTI-RUST MATERIAL.

COLUMNA DESPENSERO SQUAD

SQUAD PANTRY COLUMN



Q-411NML/45	450 mm (L414xP500xH1200/1450 mm)
Q-411NML/60	600 mm (L564xP500xH1200/1450 mm)
Q-412NML/45	450 mm (L414xP500xH1900/2100 mm)
Q-412NML/60	600 mm (L564xP500xH1900/2100 mm)
T-Q423L/45	Alf. antideslizante / Non-slip mat
T-Q424L/60	Alf. antideslizante / Non-slip mat



Una cocina cómoda debe estar bien distribuida en el ambiente y bien organizada en el interior del mobiliario. Gracias a nuestra Pantry Column tenemos la oportunidad de mejorar la visibilidad de los objetos.

A comfortable kitchen must be well distributed within the environment and well organized inside the furniture. Thanks to our Pantry Column we have the opportunity to improve the visibility of the objects..

Acabado antracita PRETRATADO CON MATERIAL ANTIOXIDANTE.
Anthracite finish PRETREATED WITH ANTI-RUST MATERIAL.

SISTEMA BARRA A PARED Sous-Chef RAIL

Sous-Chef RAIL WALL SYSTEM



Cod.	L / W
6SCNEBA601PZ	600
6SCNEBA901PZ	900
6SCNEBA1201PZ	1200

El kit BP60 consta de:

- 1 barra de aluminio pintada de 60 mm
- 2 ganchos de aluminio pintados
- 2 soportes para la fijación

The BP60 kit consists of:

- 1 60 mm painted aluminum bar
- 2 painted aluminum hooks
- 2 supports for fixation

El kit BP90 consta de:

- 1 barra de aluminio pintada de 90 mm
- 3 ganchos de aluminio pintados
- 2 soportes para la fijación

The BP90 kit consists of:

- 1 90 mm painted aluminum bar
- 3 painted aluminum hooks
- 2 supports for fixation

El kit BP120 consta de:

- 2 barras de aluminio pintadas de 60 mm
- 4 ganchos de aluminio pintados
- 3 soportes para la fijación

The BP120 kit consists of:

- 2 60 mm painted aluminum bar
- 4 painted aluminum hooks
- 3 supports for fixation

6SCNEPRBP1PZ

Color / Colour
Negro / Black



W.246
D. 123
H. 44

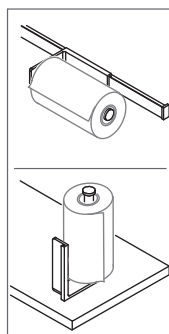

6SCG4BOBP1PZ

Color / Colour
Gris Orion / Orion Grey



W.221
D. 127
H. 88

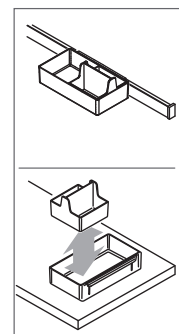

EXTRAIBLE Sous-Chef SLIM

Sous-Chef SLIM

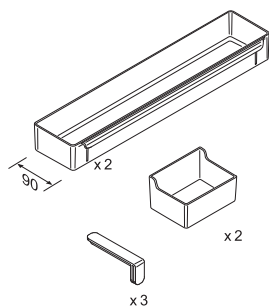

Cod.	🔗	L / W	P / D	H / H
6SCG4SLIM1PZ	150	108	506	680

SOUS CHEF SLIM

- Fijación al lateral del mueble y a la puerta
- Guías de extensión total
- Cierre asistido y amortiguado
- Estructura metálica
- Bandejas de plástico extraíbles

SOUS CHEF SLIM

- Door Fixing to mounting the side of the cabinet
- Full extension slides
- Soft closing
- Metal frame
- Removable plastic trays

W. 108
D. 506
H. 680



Gollinucci

EXTRAIBLE Sous-Chef SMART

Sous-Chef SMART



Cod.	↔	L / W	P / D	H / H
6SCG4SMART1	300	136	500	334

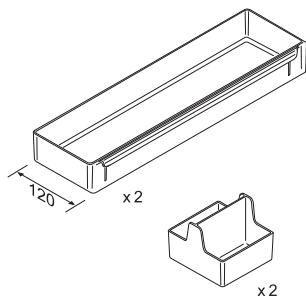

SOUS CHEF SMART

- Fijación al lateral del mueble
- Guías de extensión total
- Cierre asistido y amortiguado
- Estructura metálica
- Bandejas de plástico extraíbles
- Extracción manual

SOUS CHEF SMART

- Door Fixing to mounting the side of the cabinet
- Full extension slides
- Soft closing
- Metal frame
- Removable plastic trays



OPCIONAL / OPTIONAL
Portacuchillos madera
 Knife block
6SCPCOL

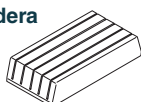

W. 136
 D. 500
 H. 334



10 min min 300 mm

Gollinucci

EXTRAIBLE Sous-Chef TRAY PLUS

Sous-Chef TRAY PLUS

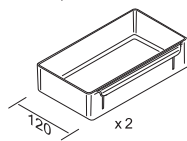
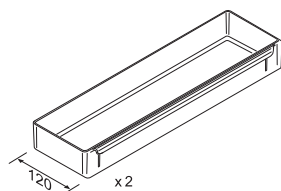

OPCIONAL / OPTIONAL
Portacuchillos madera
 Knife block
6SCPCOL

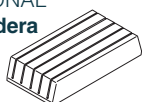

Cod.	✂	L / W	P / D	H / H
6SCG4TRAYP1	300	255	526	685

SOUS CHEF TRAY PLUS

- Fijación al fondo del mueble y a la puerta
- Guías de extensión total
- Cierre asistido y amortiguado
- Estructura metálica
- Bandejas de plástico extraíbles

SOUS CHEF TRAY PLUS

- Fixing to the bottom of the cabinet & Door mounting
- Full extension slides
- Soft closing
- Metal frames
- Removable plastic trays

W. 255
 D. 526
 H. 685



12 min min 300 mm

Gollinucci

EXTRAIBLE PANERO Sous-Chef TRAY PLUS BAG

Sous-Chef TRAY PLUS WIHT BREAD BAG

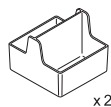
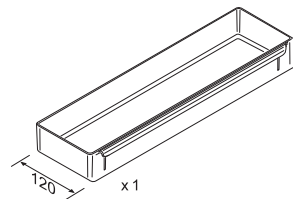
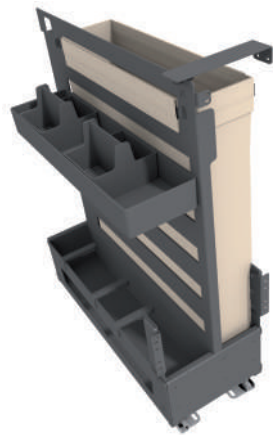

OPCIONAL / OPTIONAL
Portacuchillos madera
Knife block
6SCPCOL

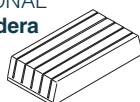

Cod.	✂	L/W	P/D	H/H
6SCG4TRAYPPB	300	255	526	685

SOUS CHEF TRAY PLUS BAG

- Fijación a la parte inferior del mueble
- Guías de extensión total
- Cierre asistido y amortiguado
- Extracción manual
- Estructura metálica
- Bandejas de plástico extraíbles
- Bolsa de pan en lona natural

SOUS CHEF TRAY PLUS BAG

- Fixing to the bottom of the cabinet
- Full extension slides
- Soft closing
- Manual extraction
- Metal frame
- Removable plastic trays
- Natural canvas bread bag

W. 255
D. 526
H. 685



12 min min 300 mm

Gollinucci

EXTRAIBLE Sous-Chef ONE

Sous-Chef ONE



Cod.	✂	L / W	P / D	H / H
6SCG4CE01	300	255	506	628

SOUS CHEF ONE

- Fijación al fondo del cajón
- CAJÓN NO INCLUIDO
- Estructura metálica
- Bandejas de plástico extraíbles

SOUS CHEF ONE

- Fixing to the bottom of the drawer
- DRAWER NOT INCLUDED
- Metal frame
- Removable plastic trays

OPCIONAL / OPTIONAL

Portacuchillos madera

Knife block

6SCPCOL

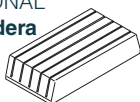

W. 255
D. 506
H. 628



10 min



min 300 mm

Gollinucci

EXTRAIBLE Sous-Chef ONE BAG

Sous-Chef ONE WIHT BREAD BAG



Cod.	✎	L/W	P/D	H/H
6SCG4CEPB01	300	255	506	628

SOUS CHEF ONE

- Fijación al fondo del cajón
- **CAJÓN NO INCLUIDO**
- Estructura metálica
- Bandejas de plástico extraíbles
- Bolsa de pan en lona natural

SOUS CHEF ONE

- Fixing to the bottom of the drawer
- **DRAWER NOT INCLUDED**
- Metal frame
- Removable plastic trays
- Natural canvas bread bag

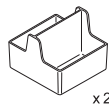
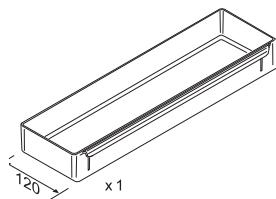

OPCIONAL / OPTIONAL
Portacuchillos madera
Knife block
6SCPCOL

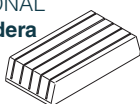

W. 255
D. 506
H. 628



10 min min 300 mm

EXTRAIBILE RINCÓN Sous-Chef CORNER

Sous-Chef CORNER PULL-OUT



EXTRAIBILE RINCÓN Sous-Chef CORNER

Sous-Chef CORNER PULL-OUT

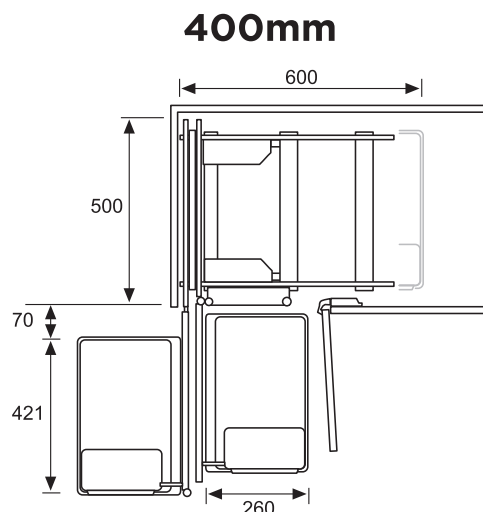
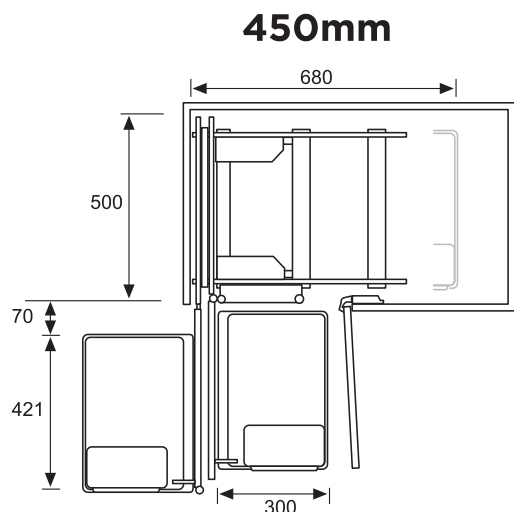
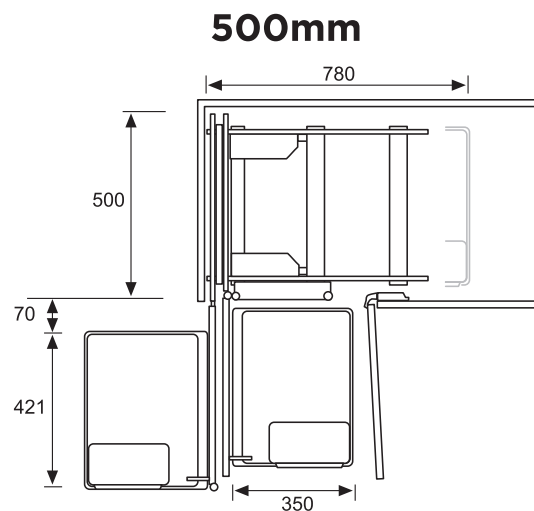
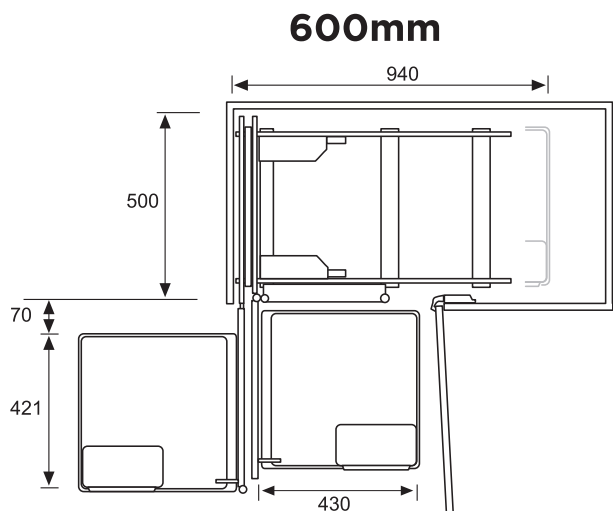

SOUS CHEF CORNER

- Máxima seguridad durante el uso
- Aprovechamiento máximo del espacio
- Guías probadas a 100.000 ciclos
- Bandejas fácilmente extraíbles para facilitar la limpieza
- Se suministra con dos bandejas multiusos

SOUS CHEF CORNER

- Maximum safety during use
- Maximum use of space
- 100000 cycles tested slides
- Easily removable trays for easy cleaning
- Equipped with two multi-use trays

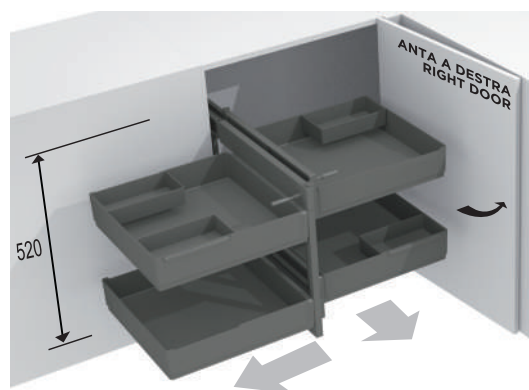

Cod.	✂	L / W	P / D	H / H
6SCG4CO40R1	400	600	500	520
6SCG4CO45R1	450	680	500	520
6SCG4CO50R1	500	780	500	520
6SCG4CO60R1	600	940	500	520

EXTRAIBLE COLUMN Sous-Chef HIGH

Sous-Chef HIGH PULL-OUT



EXTRAIBLE COLUMNA Sous-Chef HIGH

Sous-Chef HIGH PULL-OUT

b a s e 400 mm



W. 333
D. 500
H. min.1946
H. max.2212



15 min



300 mm

b a s e 300 mm



W. 233
D. 500
H. min.1946
H. max.2212



15 min



400 mm

Cod.	➤	L / W	P / D	H / H
6SCG4CADM30	300	233	500	1946/2212
6SCG4CADM40	400	333	500	1946/2212

SOUS CHEF HIGH

- Estructura de metal pintado
- Fijación a la hoja
- Cinco estantes extraíbles de plástico y metal, que se pueden colocar a varias alturas
- Se suministra con dos bandejas multiusos*
- Marco telescópico

SOUS CHEF HIGH

- Painted metal structure
- Door mounting
- Five removable plastic and metal shelves, which can be positioned in various heights
- Equipped with two multi-use trays*
- Telescopic frame

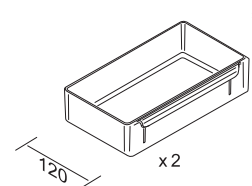

reddot winner 2022

Gollinucci

EXTRAIBLE COLUMN Sous-Chef HIGH

Sous-Chef HIGH PULL-OUT



EXTRAIBLE COLUMN Sous-Chef HIGH

Sous-Chef HIGH PULL-OUT

b a s e 600 mm



W. 535
D. 492
H. 1906



15 min



600 mm



automatic

b a s e 500 mm



W. 435
D. 492
H. 1906



15 min



500 mm



automatic

b a s e 450 mm



W. 385
D. 492
H. 1906



15 min



450 mm



automatic

Cod.	W	L / W	P / D	H / H
6SCG4CAAB45	450	385	492	1906
6SCG4CAAB50	500	435	492	1906
6SCG4CAAB60	600	535	492	1906

SOUS CHEF HIGH

- Estructura de metal pintado
- Sistema de apertura automática con la puerta
- Cinco estantes extraíbles de plástico y metal, que se pueden colocar a varias alturas
- Se suministra con dos bandejas multiusos*

SOUS CHEF HIGH

- Painted metal structure
- Automatic pull-out system
- Five removable plastic and metal shelves, which can be positioned in various heights
- Equipped with two multi-use trays*

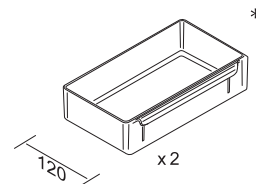

- Anillo de metal pintado y soportes de plástico
- Incrementa la altura de almacenamiento de la bandeja en 50 mm
- Disponible para todas las bases
- Painted metal ring and plastic supports
- increases the storage height of the tray by 50 mm
- Available for all bases



reddot winner 2022

Gollinucci





SOLUCIONES TÉCNICAS PARA EL MUEBLE, S.L.

Pol.Ind. Río do Pozo Sector IV - Rúa dos Toneleiros, W6
15.573 - Narón
A Coruña

t: 981 109 585

f: 881 936 683

e-mail: info@stmsoluciones.eu

web: www.stmsoluciones.eu

